

# Multi-Wavelength Illuminator OTLA-0130 Preliminary

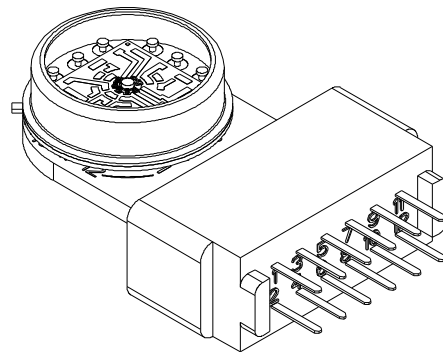

## PRODUCT DESCRIPTION

The OTLA-0130 incorporates a white LED along with additional monochromatic LED die for supplementing the spectral output of the white LED. The OTLA-0130 has an optical emitting area of 2 mm in diameter. The small emitting area allows it to be easily integrated into optical systems with focusing optics or fiber optics. Each LED wavelength (white, 395 nm, 470 nm, 630 nm and 660 nm) can be individually addressed for separate pulsing and intensity balancing.

Electrical termination is through an industry standard edge connector or by soldering wires directly to the circuit board.

Potential applications for the OTLA-0130 broadband white LED include: fluorescence, absorbance, transmittance, reflectance and color metric measurements. The OTLA-0130 may be customized to fit specific applications by modifying or adding additional LED wavelengths into the existing package.

## Product Requirements

### Environmental Requirements/ Absolute Maximum Ratings

Parameter	Min.	Typ.	Max.	Units
Storage Temperature	-20	-	70	°C
Operating Temperature	0	-	60	°C
T <sub>j</sub> max- Colored Die	-	-	100	°C
T <sub>j</sub> max – White Die	-	-	130	°C
White Die - All Colored Die at 20mA per die, T <sub>amb</sub> = 25 °C Continues Mode	-	-	250	mA
RoHS Compliance	Compliant per Directive 2002/95/EC dated 01/27/03			



OPTO TECHNOLOGY, INC.

160 E. Marquardt Drive, Wheeling, IL 60090  
Phone: (847) 537-4277 Fax: (847) 537-4785  
Website: [www.optotech.com](http://www.optotech.com)

# Multi-Wavelength Illuminator OTLA-0130 Preliminary

## Optical Requirements

### Wavelength & Flux Specifications <sup>1</sup>

Nominal Wavelength Typical, (nm)	Peak Wavelength Typical, (nm)	Forward Current per Die (mA)	Full Width Half Max, Typical (nm)	Radiometric Flux, Typical (mW)	Photometric Flux, Typical (Lumens)
395	396 <sup>2</sup>	20	15.4	9.7	0.02
470	470 <sup>2</sup>	20	25.0	4.7	0.27
630	634	20	16.5	3.6	0.51
660	657 <sup>2</sup>	20	25.0	5.1	0.23
White Chip	445	350	24.7	26.5	8.8

<sup>1</sup> Optical power measurements made within 3 seconds of turn-on at approximately 25°C.

<sup>2</sup> Both die powered at 20mA each.

## Electrical Requirements

### Forward Voltage

Wavelength (nm)	Current per Die (mA)	Vf, Typical (V)
395	20	3.7
470	20	3.3
630	20	2.1
660	20	2.0
White Chip	350 <sup>3</sup>	3.8

<sup>3</sup>Continuous drive current without supplemental die



OPTO TECHNOLOGY, INC.

160 E. Marquardt Drive, Wheeling, IL 60090  
Phone: (847) 537-4277 Fax: (847) 537-4785  
Website: [www.optotech.com](http://www.optotech.com)

# Multi-Wavelength Illuminator OTLA-0130 Preliminary

## Connector Pin Layout

Pin Number	Function
1	630nm Anode
2	470nm Anode
3	Common Cathode (2X 395nm, 2X 470nm, 630nm, White Chip)
4	470nm Anode
5	NC
6	White Chip Anode
7	NC
8	395nm Anode
9	660nm Cathode
10	395nm Anode
11	Common Anode (2X 660nm)
12	660nm Cathode

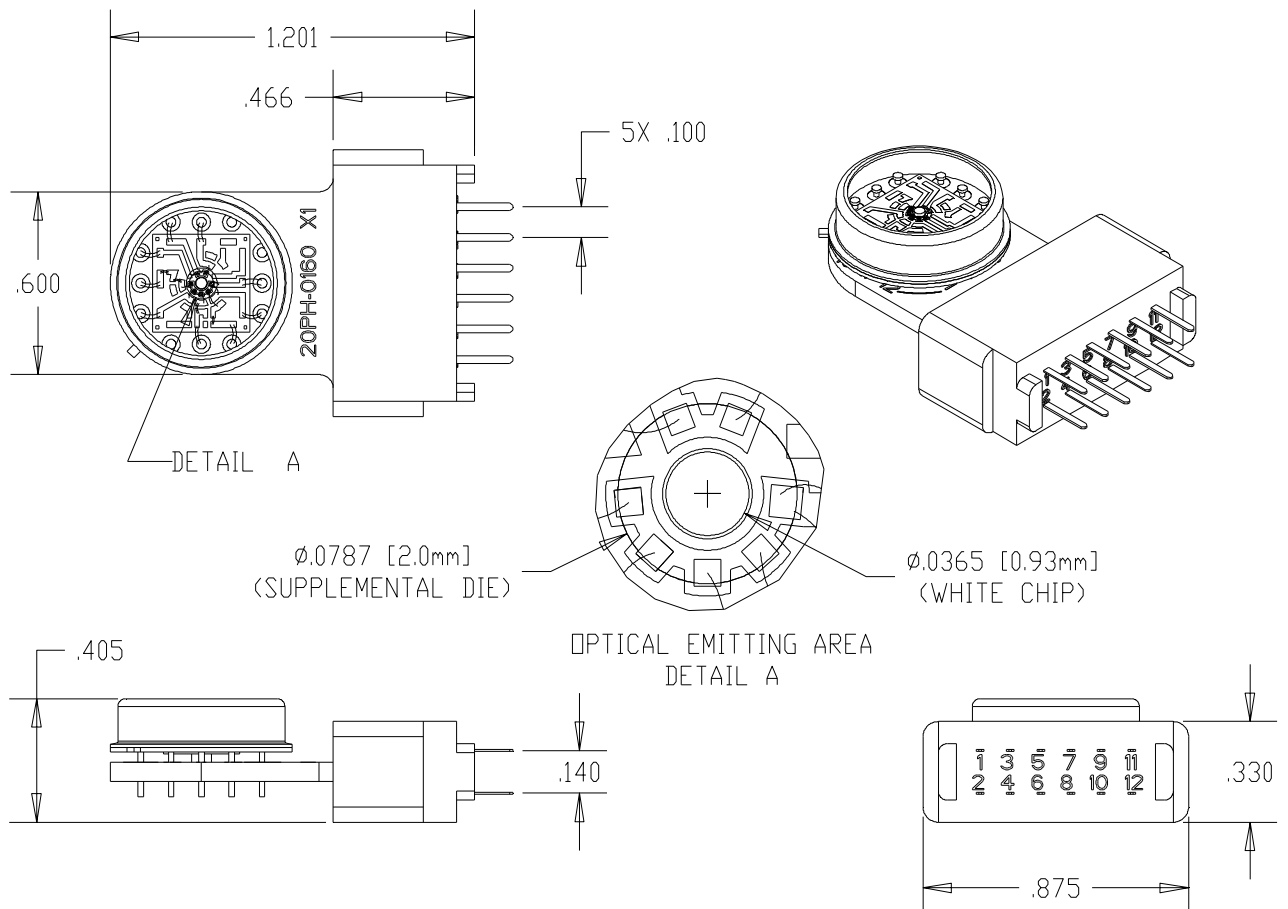

OPTO TECHNOLOGY, INC.

160 E. Marquardt Drive, Wheeling, IL 60090  
 Phone: (847) 537-4277 Fax: (847) 537-4785  
 Website: [www.optotech.com](http://www.optotech.com)